



**PULSE MODULATING  
ANTI-SWEAT CONTROL**

**INSTALLATION AND OPERATION  
MANUAL**

**PN# 410-0001  
REV. 3.0**



## **INSTALLATION AND OPERATION MANUAL**



**All Rights Reserved.**

The information in this manual has been carefully reviewed and is believed to be accurate, however APEX Controls, Inc. assumes no responsibility for any errors contained herein. APEX Controls, Inc. may not be held liable for any damages (direct or indirect) resulting from any error of omission in this manual. APEX Controls, Inc. reserves the right to make changes to this manual and the products described herein at any time without notice.

2700 HWY 42 North

McDonough, GA 30253

PH: 770-914-8550

Fax: 770-914-8555

Service: [service@ApexControlsInc.com](mailto:service@ApexControlsInc.com)

Sales: [sales@ApexControlsInc.com](mailto:sales@ApexControlsInc.com)

# Table of Contents

---

Product Description.....	3
Installation.....	4
-Mounting	
-Field Wiring	
-Sensor Connections	
Operation.....	8
-Displays	
-Adjustments	
Trouble Shooting Procedures.....	12
Circuit Summary Chart.....	14



## Product Description

---

The SweatMiser™ is an anti-sweat heater controller designed to dramatically reduce the cost of operating low temperature glass door cases. The SweatMiser is a stand-alone unit that uses solid state relay technology to quietly modulate the door heaters at their most energy efficient rate.

Anti-sweat heaters typically operate 24 hours per day at full load regardless of store conditions. By monitoring the dewpoint of the store, the SweatMiser is able to pulse these heaters every second. Solid state relays make this rapid pulsing of the heaters possible. The lower the dewpoint, the greater the energy savings.

The SweatMiser is capable of pulsing up to 24 anti-sweat circuits with a maximum of 30 amps per channel. The “no programming” setup allows for easy installation and service. Simply set the pulse rate and dewpoint rotary dials and the SweatMiser is ready to operate.

# Installation

---

1. Locate the power distribution panels and wiring raceway containing the power feeds for the anti-sweat heaters. Whenever possible, mount the SweatMiser panel directly over this raceway. This facilitates the wiring of the heaters through the SweatMiser. Make the proper size conduit connections between the raceway and panel. (See Fig. 1 on page 5).
2. Install the combination humidity/temperature sensor on the pole nearest the aisle of the glass door cases. The sensor should be located 8 feet above floor level.
3. Use 22 AWG 6 conductor shielded cable to connect the combination humidity/temp sensor to the SweatMiser processor board. (See Fig. 2 on page 6).
4. Locate the anti-sweat circuits to be fed through the SweatMiser.  
**NOTE: Be sure all power is disconnected from each heater circuit.**  
Proceed with wiring the heaters to the terminal strips provided for line and load. (See Fig. 2 on page 6).
5. Connect 120 VAC (15 amp circuit) power supply to the unit as shown in Fig. 2. (240 VAC power supplies are available if required).
6. Label all circuit numbers used with the corresponding relay channel numbers on the chart provided on the inside of the SweatMiser panel door.
7. Turn on the power supply breaker feeding the panel and note the LED readouts on the SweatMiser processor. Turn on the heater circuits and check for proper amperage and relay pulsing. Refer to the “Operations” portion of this manual for further information.

DIMENSIONS: 24" x 24" x 6.75" – SWM-16  
24" x 30" x 6.75" – SWM-24

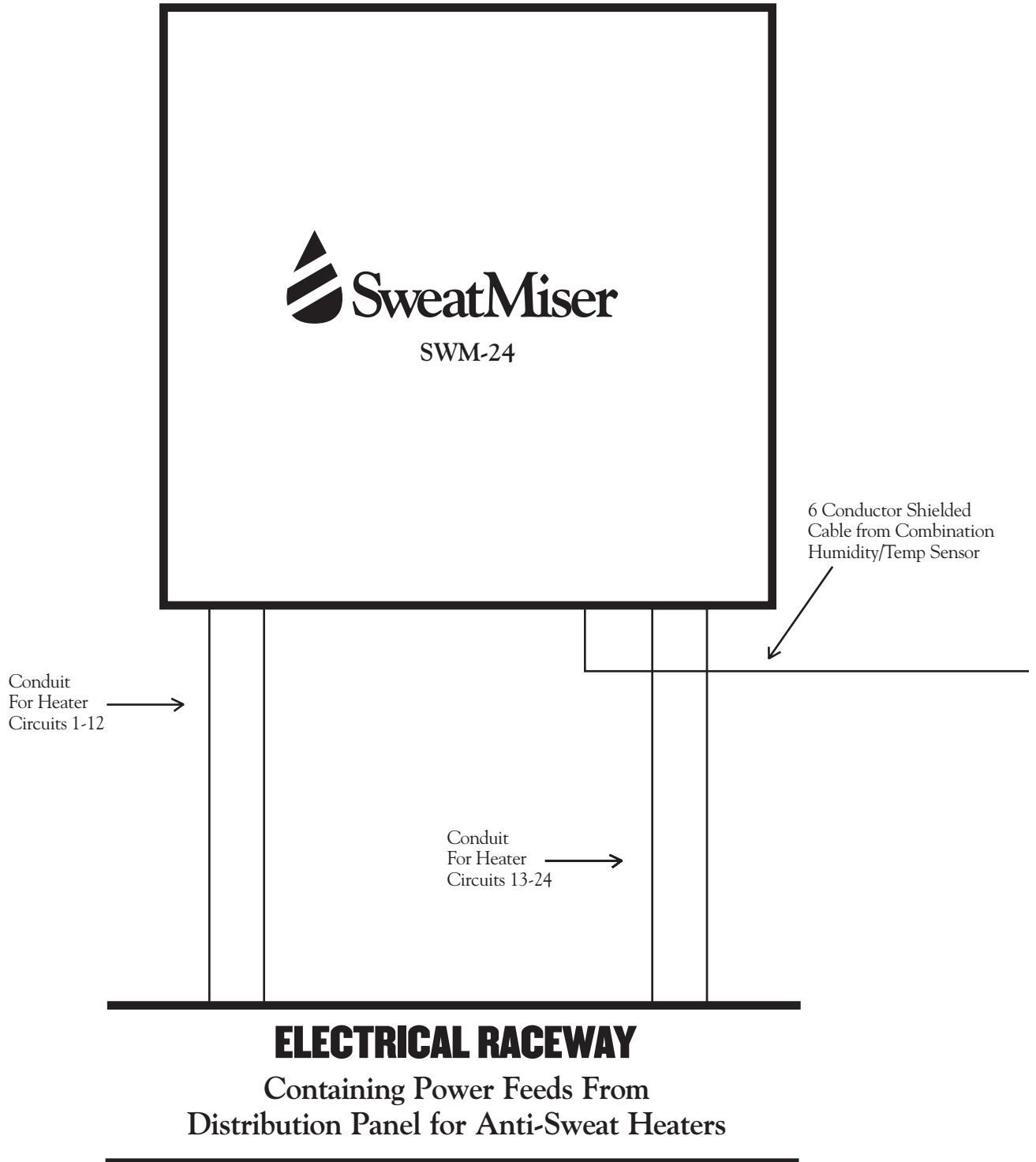
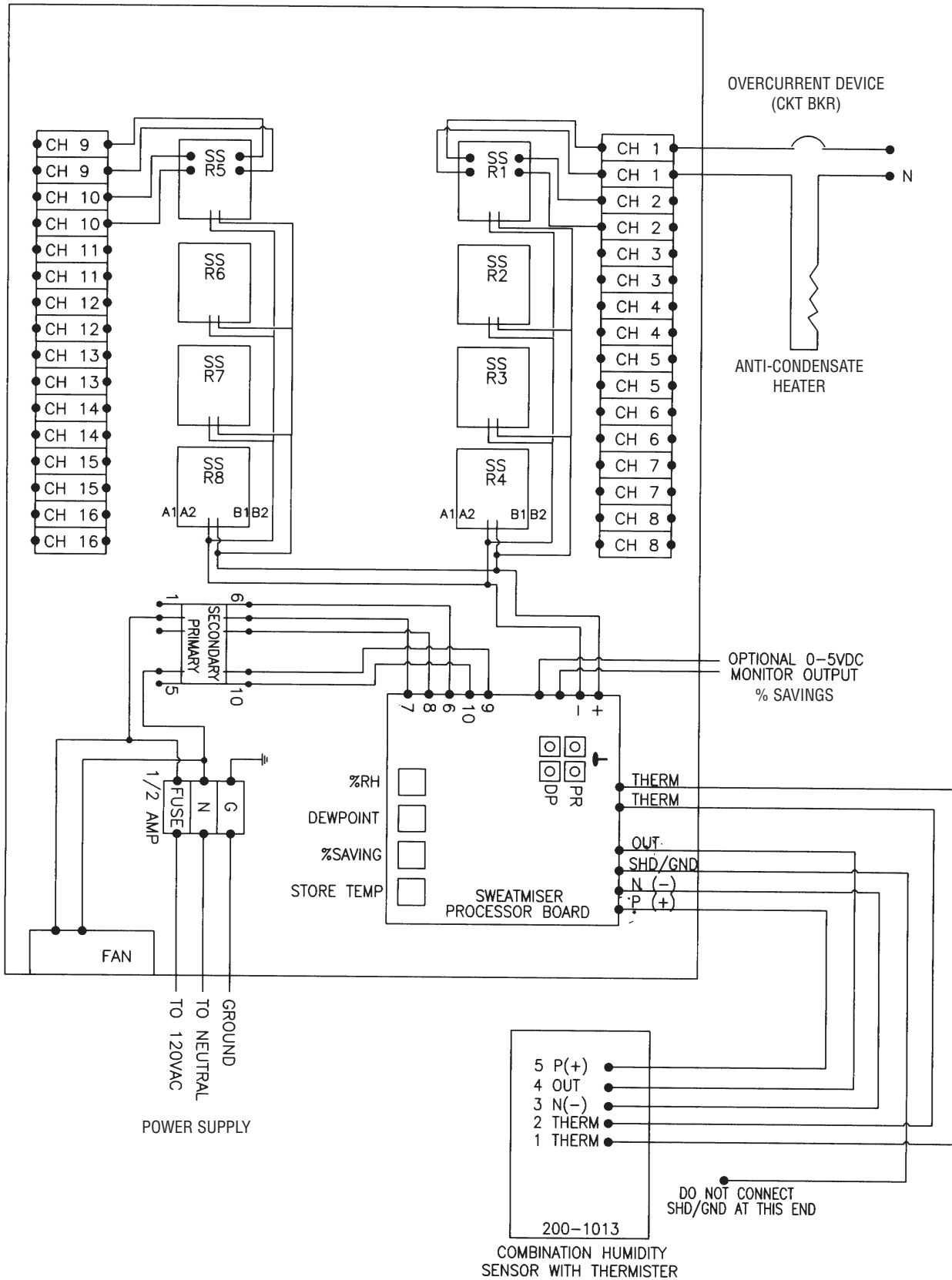
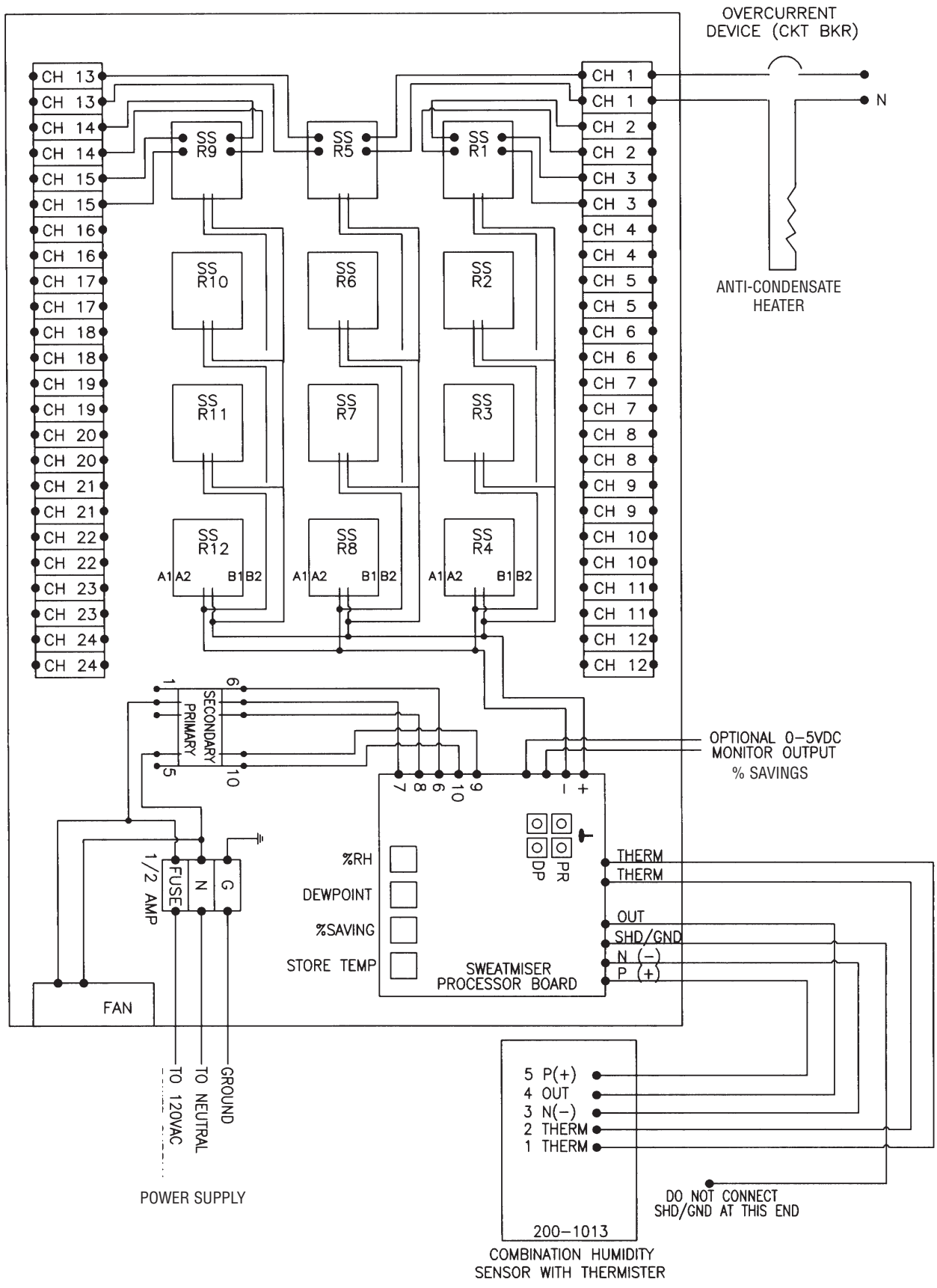

Fig. 1



SWM-16  
Fig. 2



SWM-24  
Fig. 3

# Operation

---

## Displays

The SweatMiser processor board shown in Fig. 4 on page 10 displays readouts for Relative Humidity, Dewpoint, Percent Savings and Store Temperature. Each of these values are updated approximately every 5 seconds.

### HUMIDITY

Displayed as %RH, this readout is adjustable by turning the Relative Humidity Sensor Calibration Dial shown in Fig. 4. Simply use a sling Psychrometer or an accurate electronic RH sensor to establish the store RH near the location of the installed RH sensor. Adjust the pot until the SweatMiser readout matches the sling readout.

### DEWPOINT

The SweatMiser calculates Dewpoint using the RH and temperature sensor inputs and a built-in psychrometric chart. Dewpoint is displayed as °F and is used to determine the pulse rate to the solid state relays.

### PERCENT SAVINGS

This display shows the energy savings accomplished by the SweatMiser at that instant. The percentage is calculated from the pulse rate being sent to the solid state relays. For example, if the relays are being cycled ON 6/10 of a second and OFF for 4/10 of a second, the savings would be 40%. A 0-5 VDC analog output is provided for optional remote monitoring by electronic equipment. The terminals for this output are shown in Fig. 4.

### TEMPERATURE

The integral 10 k ohm thermister located in the combination humidity/temp sensor provides the current store temperature in degrees Fahrenheit. If required, this readout may be calibrated using the Temperature Sensor Calibration Dial shown in Fig. 4.

# Adjustments

The SweatMiser comes factory pre-set to operate in any store with no adjustments necessary. However, to optimize your energy savings you may want to make a couple of simple adjustments. There are two sets of parameter adjustments that can be made by setting four dials. These dials are shown on Fig. 4 and are used to set the pulse rate and dewpoint limits.

The two lower dials determine the dewpoint temperature range. Dial numbers represent 10°F increments and are factory set at 2 and 6.

The two top dials determine the upper and lower limits to which the pulse rate may be adjusted. The numbers on the dials represent tenths of second pulse rates and are factory set to 2 and 9.

Table 1 on page 11 shows examples of various setpoint parameters. Keep in mind that the idea is to increase savings as much as possible without having your glass doors fogging or sweating. Store environment plays a large role in how you operate the SweatMiser. You may experiment with the factory setpoints to determine the most efficient operation of your anti-sweat heaters.

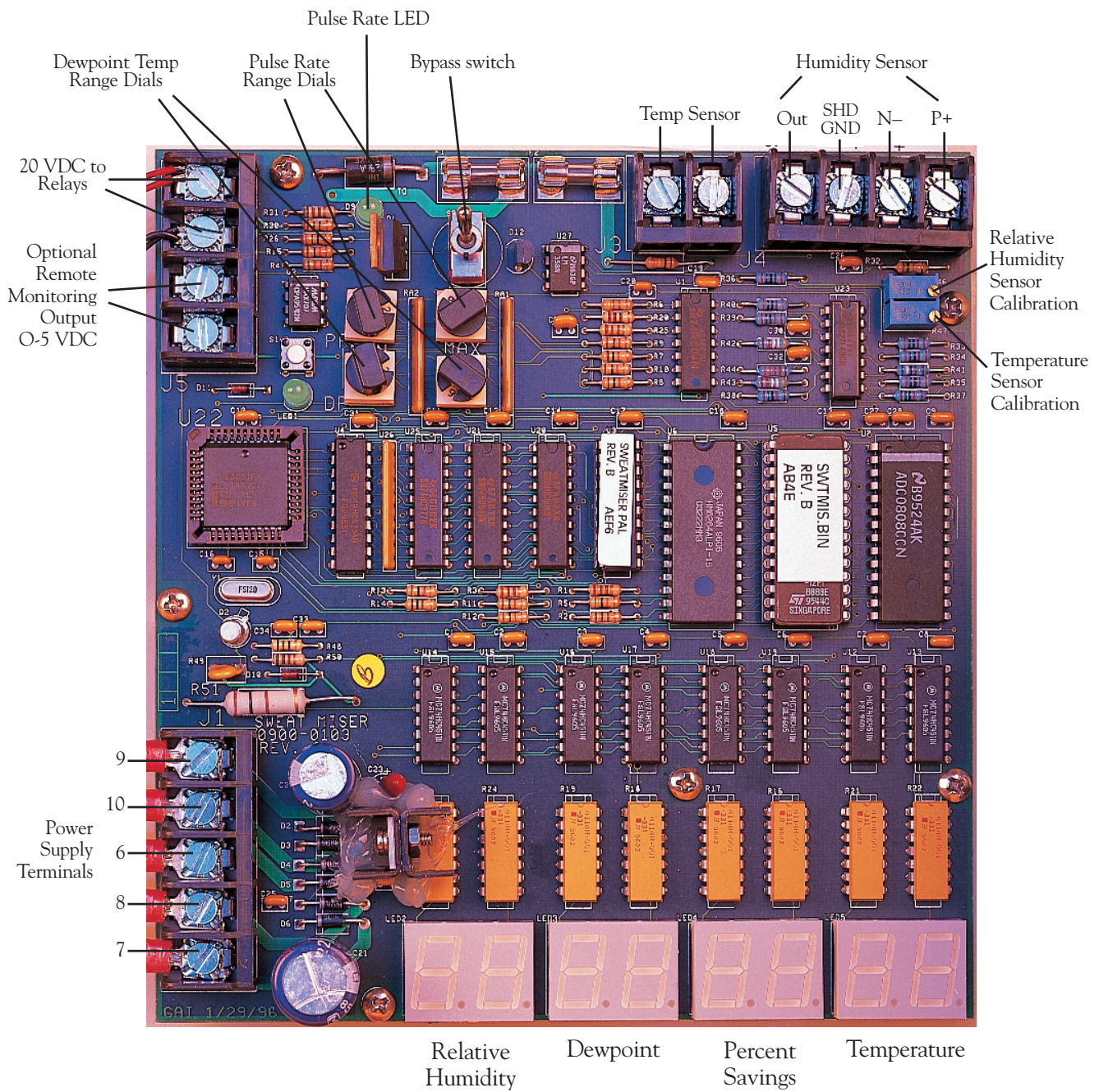

## SweatMiser Processor Board

Fig. 4

## EXAMPLE

	<u>Factory Setpoints</u>	<u>Progressive Setpoints</u>
<u>Dewpoint Limits</u>		
Upper Limit	60°F	80°F
Lower Limit	20°F	10°F
<u>Pulse Rate Limits</u>		
Upper Limit	90%	80%
Lower Limit	20%	0%

TABLE 1

# Trouble Shooting Procedures

---

## ALL DOORS SWEATING

1. Check processor to ensure LED displays are lit.
2. If not, check 120 VAC power supply to panel and 24 VAC output of transformer to SweatMiser processor.
3. If LED's are lit, verify proper readings.
4. If any readings are out of range, reset the processor by cycling the power off then on again.
5. Readings should be correct or within a reasonable range that can be calibrated. If not, the board must be replaced.
6. Once the board has been replaced or reset, verify that all relays are pulsing by checking each load at the solid state relay with an analog type amp probe. Each load should be pulsing along with the green pulsing LED on the processor.

## ONE SECTION OF DOORS SWEATING

1. Refer to #6 above and determine which load is not being pulsed through the solid state relays by checking each with an amp probe.
2. If a load is not pulsing, verify that the circuit breaker to that load is not tripped. If the power supply is OK, turn off the power to the affected relay and move the wires for that circuit to another relay that has a spare set of unused contacts. If no spare points are available, the relay must be replaced.

### ONE SECTION OF DOORS SWEATING (continued)

3. Reapply power and check the load for proper pulsing.
4. If all loads are cycling properly and a section of doors is sweating, the problem is outside the SweatMiser. Check for loose wires in all connections in wireway. If all are OK, the case heater is most likely the problem. Report this to store management so that the proper maintenance personnel are alerted.

# CIRCUIT SUMMARY CHART

Dist. Panel	Circuit #	Circuit Name	SweatMiser Channel #	Amperage
			1	A
			2	A
			3	A
			4	A
			5	A
			6	A
			7	A
			8	A
			9	A
			10	A
			11	A
			12	A
			13	A
			14	A
			15	A
			16	A
			17	A
			18	A
			19	A
			20	A
			21	A
			22	A
			23	A
			24	A

**APEX**  
**Controls, Inc.**

2700 HWY 42 North • McDonough, GA 30253 • PH: 770-914-8550 • Fax: 770-914-8555  
Service: [service@ApexControlsInc.com](mailto:service@ApexControlsInc.com) • Sales: [sales@ApexControlsInc.com](mailto:sales@ApexControlsInc.com)